



Better Air is Our Business®

AmericanAirFilter®

SAAF Side Access Housings (SAH)

with SAAF Cassette Gas-phase Chemical Filters

Installation, Operation, and Maintenance Instructions

Table of Contents

1.0 Introduction

- 1.1 About this document
- 1.2 Packaging and shipping, receiving and inspection, handling, and storage
- 1.3 Product descriptions
- 1.4 Product model designations
- 1.5 Product drawings
- 1.6 Assembly – general comments
- 1.7 Related system equipment

2.0 Principles of Operation

3.0 Installation Instructions

- 3.1 Space requirements
- 3.2 Foundations and anchoring
- 3.3 Typical Side Access Housing (SAH) details
- 3.4 General filter system installation procedure
- 3.5 Preparation for filter installation
- 3.6 Pre-filter Installation
- 3.7 Gas-phase chemical filter installation
- 3.8 After-filter installation
- 3.9 High-efficiency filter installation
- 3.10 Latch SAH doors
- 3.11 Pressure gauge
- 3.12 Fans

4.0 Start-up Instructions

5.0 Maintenance

- 5.1 Prefilter
- 5.2 After-filter
- 5.3 High-efficiency final filters
- 5.4 Gas-phase filter monitoring
- 5.5 Removal and replacement of particulate and gas-phase chemical filters

5.6 Disposal of used filters

- 5.7 Gas-phase chemical filter cassette face sealing gaskets
- 5.8 After-filter and high-efficiency particulate filter sealing gaskets
- 5.9 Access door sealing gaskets
- 5.10 General system maintenance

6.0 Troubleshooting

- 6.1 High pressure drop reading across the filter system
- 6.2 Visible discharge of particulate
- 6.3 Odors and smells

7.0 Spare Parts List

8.0 Equipment Characteristics, Operating Weights, and Shipping Weights

9.0 Technical Guidelines

- 9.1 Fan selection and sizing

1.0 Introduction

1.1 About this Document

This document contains the information necessary to properly receive, assemble, install, operate, and maintain the AAF Side Access Housing (SAH) filter system and filters. The purchaser, installer, and operator of the filter system **MUST** read and comply with this document in its entirety prior to installation of the equipment and its operation. Failure to comply with the requirements of this manual may void the product warranty.

CAUTION

These instructions are specific to the AAF Side Access Housing (SAH) filter system and filters. All ancillary tasks including, but not limited to, electrical and mechanical work, equipment handling, and safety procedures must be performed in accordance with industry accepted practice and all relevant local, state, and federal government codes, laws, and policies.

1.2 Packaging and Shipping, Receiving and Inspection, Handling and Storage

1.2.1 Packaging and Shipping: Unless otherwise defined in the purchase order and agreed by AAF, the SAH filter housing and filters are packaged for domestic transit and shipped FOB the AAF factory. The method of shipment will be as specified in the customer's purchase order to AAF.

1.2.2 Receiving and Inspection: Obtain a copy of the purchase order, the product drawing that was submitted by AAF in association with the order, and a copy of the bill of lading, along with any other shipping papers. Upon receipt of the equipment, or any part thereof, these documents shall be used to ensure that the correct product has been received.

For maximum protection, complete the following steps upon receipt of the AAF Side Access Housing (SAH) and filters:

- Inspect the shipment and all associated documentation. Notify the carrier immediately if there is any visible damage to the packaging or the equipment, or a discrepancy in the shipping papers and, if necessary, file an immediate claim with the carrier against such damage or discrepancy.
- Confirm that the equipment received agrees with the contents of the shipping papers.
- Confirm that the shipping documents agree with the purchase order. Refer to the product drawing submitted for the order as necessary.
- If it is determined that any equipment ordered on the purchase order has not been delivered and is not accounted for in the shipping papers contact AAF International immediately by calling 1-800-477-1214. Reference the AAF control number, which will be listed on the shipping papers.

Each shipment may include:

- One or more individually packaged Side Access Housings (SAH).
- Packaged particulate filters.
- Packaged gas-phase chemical filter cassettes.

Note that the Side Access Housing (SAH) and the particulate and gas-phase filters may ship from different locations and be received at different times.

1.2.3 Handling and Storage: Following receipt, inspection, and acceptance of the equipment, and prior to installation, the Side Access Housing (SAH) and the particulate and gas-phase filters shall be handled with great care. The Side Access Housing (SAH) ships mounted on a pallet for protection during shipping and handling. It is recommended that it remain on its pallet until it has been moved to its final installation location. Only personnel experienced in rigging and handling large equipment shall be employed for this task. Small

SAH's may be moved using a forklift. A suggestion for rigging larger equipment is shown in Figure 1. Rig the housing using straps or a sling. Fasten the strapping under the skid on which the SAH ships. To prevent damage to the exterior surface of the SAH use spreader bars at all times. Position the spreader bars to keep the cables from rubbing against any part of the housing. Before hoisting make sure that the load is properly balanced.

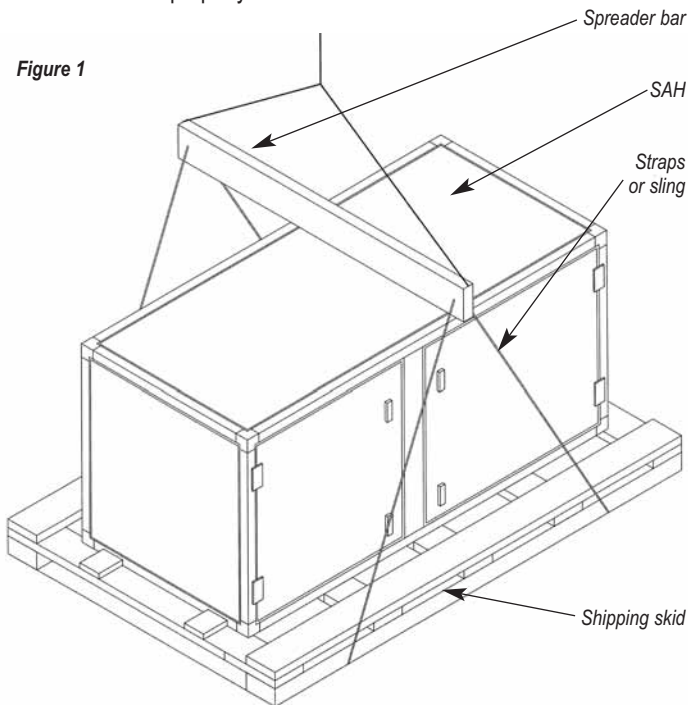

A channel base is offered as an option with the SAH. Check to see if this has been included. The channel base includes web openings for the insertion of pipes for hoisting the equipment. See below for details.

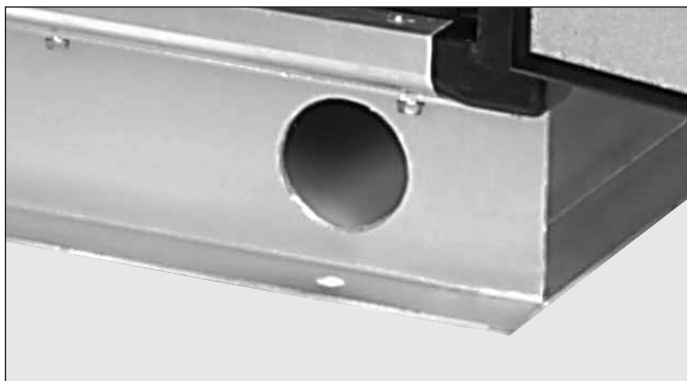

Optional channel base.

! WARNING: The housing top will not support the weight of the unit. Any attempt to support the housing from the top may result in serious equipment damage and severe personal injury. Do not walk on the top of the unit or use the top for storage of materials.

The components shall be retained and stored in their protective packaging until immediately prior to installation. Care shall be taken to ensure that the packages are not dropped or subjected to any impact loads.

At all times the equipment shall be protected from exposure to weather. The equipment shall be stored in a clean, dry, temperature-controlled environment. All items shall be stored on pallets so that they are elevated above grade. Side Access Housings (SAH) shall not be stacked. Particulate and gas-phase filters, shall not be stacked more than three (3) cartons high to prevent crushing. Only particulate filters shall be stacked on particulate filters, and gas-phase filters on gas-phase filters. The gas-phase filters ship inside a carton enclosed in transparent protective plastic. Under no circumstances shall the filters be removed from this plastic protection until immediately prior to installation.

Filter products shall not be stored in areas where they may become contaminated by chemicals, either acids or alkalis, in liquid, vapor or gaseous form.

1.3 Product Descriptions

1.3.1 Side Access Housing (SAH): Each (SAH) will be received individually mounted on a shipping pallet and wrapped in plastic for protection during shipping. Depending on the size and complexity of the SAH it may ship in sections on multiple pallets. Refer to the product drawings submitted on the order for details. The SAH can be supplied in three styles, Type MD, Type HD or Type CG, depending on the style of SAAF Cassette gas-phase chemical filter that it is intended to accommodate (see 1.3.2 for details). Different internal support tracks and track spacings will be provided depending on the type of cassette to be used.

Any particular filter system will normally be assembled using only one type of cassette, Type MD, Type HD, or Type CG. Cassettes will almost never be mixed in a single-filter system. Different types of cassettes are not interchangeable within any particular filter bank.



Side Access Housing, Model SAH-202-2P-MD-2P-6F, with tracking to accommodate four (4) MD cassettes. Optional channel base is included.



Typical Side Access Housing, Model SAH-202-2P-(MD)(HD)(CG)-2P-6F. Optional channel base is included.

1.3.2 Gas-phase Chemical Filter Cassettes: Gas-phase filter cassettes are shipped in cartons and plastic bags. The carton shown below contains a single 6" high x 24" wide x 18" deep Type MD cassette which is supplied as two (2) 6" high x 12" wide x 18" deep half cassettes.



1.3.2 continued

The three (3) types of gas-phase chemical filter cassettes that can be supplied are as follows:



6" high x 24" wide x 18" deep Type MD cassette ships in two halves.



24" high x 12" wide x 12" deep Type CG cassette ships in one piece.



12" high x 24" wide x 12" deep Type HD cassette ships in two halves.

1.3.3 Particulate filters:

Prefilters and after-filters - Particulate prefilters and after-filters will typically be AAF PerfectPleat® pleated filters. Depending on the size of the Side Access Housing (SAH) ordered 24" high x 24" wide x 2" deep full size filters, 24" high x 12" wide x 2" deep or 12" high x 24" wide x 2" deep half-size filters may be supplied. PerfectPleat 2" deep filters are packaged 12 to a carton.

High efficiency filters - High efficiency filters will typically be AAF M-Pak pleated filters. Depending on the size of the Side Access Housing (SAH) ordered 24" high x 24" wide x 6" deep full size filters, 24" high x 12" wide x 6" deep or 12" high x 24" wide x 6" deep half size filters may be supplied. M-Pak filters are packaged 2 to a carton.

Note that other optional or special filter arrangements may be supplied depending on the requirements of the project. Check the purchase order and the AAF submittal drawing(s) for details.

1.4 Product Model Designations

The SAH model is designated as follows:

SAH - 202 - 2P - MD - F - MD - 2P - 6F

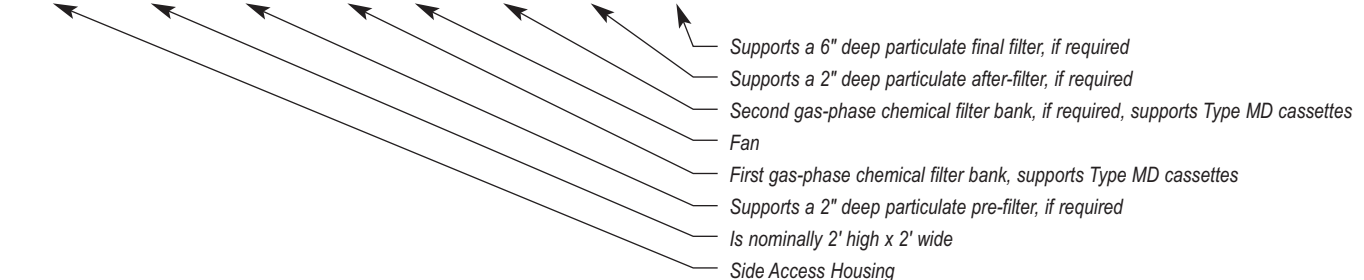

Table 1: Typical SAH Model Numbers

With gas-phase chemical filters but without particulate filters	With gas-phase chemical filters and particulate filters	With gas-phase chemical filters, particulate filters, and fans.
SAH-XXX-MD	SAH-XXX-2P-MD-2P-6F	SAH-XXX-2P-MD-F-2P-6F
SAH-XXX-MD-MD	SAH-XXX-2P-MD-MD-2P-6F	SAH-XXX-2P-MD-F-MD-2P-6F
SAH-XXX-MD-MD-MD	SAH-XXX-2P-MD-MD-MD-2P-6F	SAH-XXX-2P-MD-MD-F-MD-2P-6F
SAH-XXX-HD	SAH-XXX-2P-HD-2P-6F	SAH-XXX-2P-HD-F-2P-6F
SAH-XXX-HD-HD	SAH-XXX-2P-HD-HD-2P-6F	SAH-XXX-2P-HD-F-HD-2P-6F
SAH-XXX-HD-HD-HD	SAH-XXX-2P-HD-HD-HD-2P-6F	SAH-XXX-2P-HD-HD-F-HD-2P-6F
SAH-XXX-CG	SAH-XXX-2P-CG-2P-6F	SAH-XXX-2P-CG-F-2P-6F
SAH-XXX-CG-CG	SAH-XXX-2P-CG-CG-2P-6F	SAH-XXX-2P-CG-F-CG-2P-6F

Many combinations and permutations of housings and filter banks can be supplied depending on the application and the requirements. Typical Side Access Housing (SAH) model numbers are shown in Table 1 where -XXX- represents the size of the Side Access Housing. Housing sizes are designated as shown in the examples in Table 2.

This list by no means exhausts the possibilities and the system provided may be different from those shown here. Consult the AAF drawing that was supplied on the purchase order in question.

Table 2: Examples of Typical SAH Size Designations

Size designation	Nominal height (ft.)	Nominal Width (ft.)
SAH-404-	4	4
SAH-608-	6	8
SAH-810-	8	10

1.5 Product Drawings:

Details of some standard SAH filter systems are shown on the following AAF drawings:

SAH Module	AAF Drawing Number
SAH-XXX-MD	114D-3025681
SAH-XXX-MD-MD	114D-3025657
SAH-XXX-2P-MD-MD-6F	114D-3025608
SAH-XXX-2P-MD-MD-MD-6F	114D-3025632
SAH-XXX-HD	114D-3025756
SAH-XXX-HD-HD	114D-3025772
SAH-XXX-2P-HD-HD-6F	114D-3025798
SAH-XXX-2P-HD-HD-HD-6F	114D-3025814
SAH-201-2P-CG	114D-3027513
SAH-XXX-CG	114D-3025848
SAH-XXX-CG-CG	114D-3025830
SAH-XXX-2P-CG-CG-6F	114D-3025822

Copies of the appropriate drawings will have been supplied as part of the AAF submittals in response to the purchase order. Obtain and review the drawing(s) before proceeding with the installation of the filter system. The SAH filter system drawings include the following

details for filter system sizes 102 (1' high x 2' wide) through 810 (8' high x 10' wide):

- Overall filter system dimensions
- Shipping weights
- Operating weights
- Sizes and quantities of the particulate and gas-phase filters required
- Details of the gas-phase chemical media supplied
- Details of the particulate filters supplied
- System design airflow
- Pressure losses across the filter system at nominal airflow design velocities
- Product details

1.6 Assembly - General Comments

As indicated previously, the individual components that will comprise the filter system will ship separately and will be required to be installed on site. The AAF Side Access Housing (SAH) is a self-contained product and, consequently, a minimum amount of assembly is required. Refer to section 3.0, Installation Instructions, of this manual for further detailed instructions. Consult with an experienced installer to obtain an accurate estimate of the time, personnel and equipment resources, and tools that will be required to complete the assembly and installation of the filter system. Site assembly will be limited to

moving and lifting individual components, screwing components together, and caulking. The SAH weights and dimensions can be found on the product submittal drawings. The gas-phase chemical filters will typically have a maximum weight of approximately 40 pounds (20kg). Particulate filters will typically weigh less than the gas-phase filters.

Completion of the following preparations and provision of the following items will be the responsibility of the installer or others:

- Site preparation
- Connecting screws and hardware for attaching inlet and outlet ducts
- Provisions for anchoring and supporting the Side Access Housing, including anchor bolts, angles, straps, hangers and cradles, etc.
- Caulk, as required
- Inlet and outlet ducts, or other sheet metal parts, as required

These items will not be supplied by AAF, unless noted specifically in the AAF quotation and in the accepted customer purchase order.

NO WELDING WILL BE REQUIRED.

In general, assembly of the filter system will consist of the following:

- Preparation of the installation location
- Transportation of all components to the installation location
- Unpacking the Side Access Housing
- Installing the Side Access Housing
- Installing inlet and outlet ducts
- Unpacking and preparation of the gas-phase chemical filter cassettes
- Installing gas-phase chemical filter cassettes
- Unpacking particulate filters
- Installing particulate filters
- Cleaning the site
- Start-up and commissioning of the filter system

1.7 Related System Equipment: Ventilation systems will often include other equipment including but not limited to:

- Fan(s), if not supplied as part of the SAH
- Dampers
- Weather louvers
- Air tempering equipment
- Analog instrumentation
- Electronic instrumentation and controls

Neither the interface of these items with the filter system supplied by AAF, nor the installation, operation, and maintenance of these items is covered in this manual. Whether these items are supplied by AAF or by others, consult the documentation specific to these products for appropriate instructions.

2.0 Principles of Operation

An understanding of the design and operating principles of the Side Access Housing with Gas-phase Chemical Filters is useful for effective installation, operation, and maintenance. The system is intended to remove gaseous contaminants from intake, re-circulated, or discharged ventilation air. Examples of such contaminants may be nuisance odors and smells that may cause domestic and neighborhood discomfort and reduce workplace productivity, or harmful gases that may cause damage to health, plant and product in industrial applications. The heart of the system is the AAF SAAF Cassette. This is a high impact plastic frame that supports various types of dry, granular, chemical media between perforated screens that allow air to move through the filter. The SAAF Cassette is designed to support the chemical media in a V-bank configuration of media beds that maximizes the media exposed to the airstream, reduces the airstream velocity through the media bed, maximizes energy efficiency, and maximizes the removal of contaminants and the life of the product. The method of contaminant removal is through a combination of the physical property of adsorption and the chemical process of oxidation. AAF offers a variety of impregnated and un-impregnated dry granular media to handle a wide range of contamination problems. For more information on AAF's gas-phase air cleaning products contact your AAF representative.

The AAF Side Access Housing is one of the various framing and support systems designed to support the SAAF Cassette in the air stream and to allow easy installation, operation and maintenance of the system.

3.0 Installation Instructions

Consult the product drawing(s) submitted on this order before proceeding.

3.1 Space Requirements: A minimum of 36" clear space must be available at the access side of the Side Access Housing to perform routine maintenance and it is recommended that 24" clear space be available at the opposite side for access during installation. Additional space may be required for inlet and outlet ductwork. On large Side Access Housings, greater than 4' wide, access doors may be supplied on both sides. In this case 36" clear space must be provided on both sides for access.

3.2 Foundations, Supports, and Anchoring: The foundation and/or supports must be designed to be adequate to support the filter system operating weight, and any seismic, live or other loads (if any), with a sufficient factor of safety as determined to comply with the requirements of all applicable governing codes, standards, and laws. Ensure that the foundation or support surface is level and smooth before proceeding. The filter system is designed for operation in indoor or, with appropriate modifications to resist weather, outdoor locations. The equipment is not specifically designed to resist and operate under unusual dynamic loading situations such as high winds or earthquake conditions. If the equipment is required to function in such circumstances special precautions may be required to ensure that the equipment will remain intact, anchored, and functioning. If this situation applies consult with a qualified professional engineer before installing the equipment.

3.3 Typical SAH Housing Details

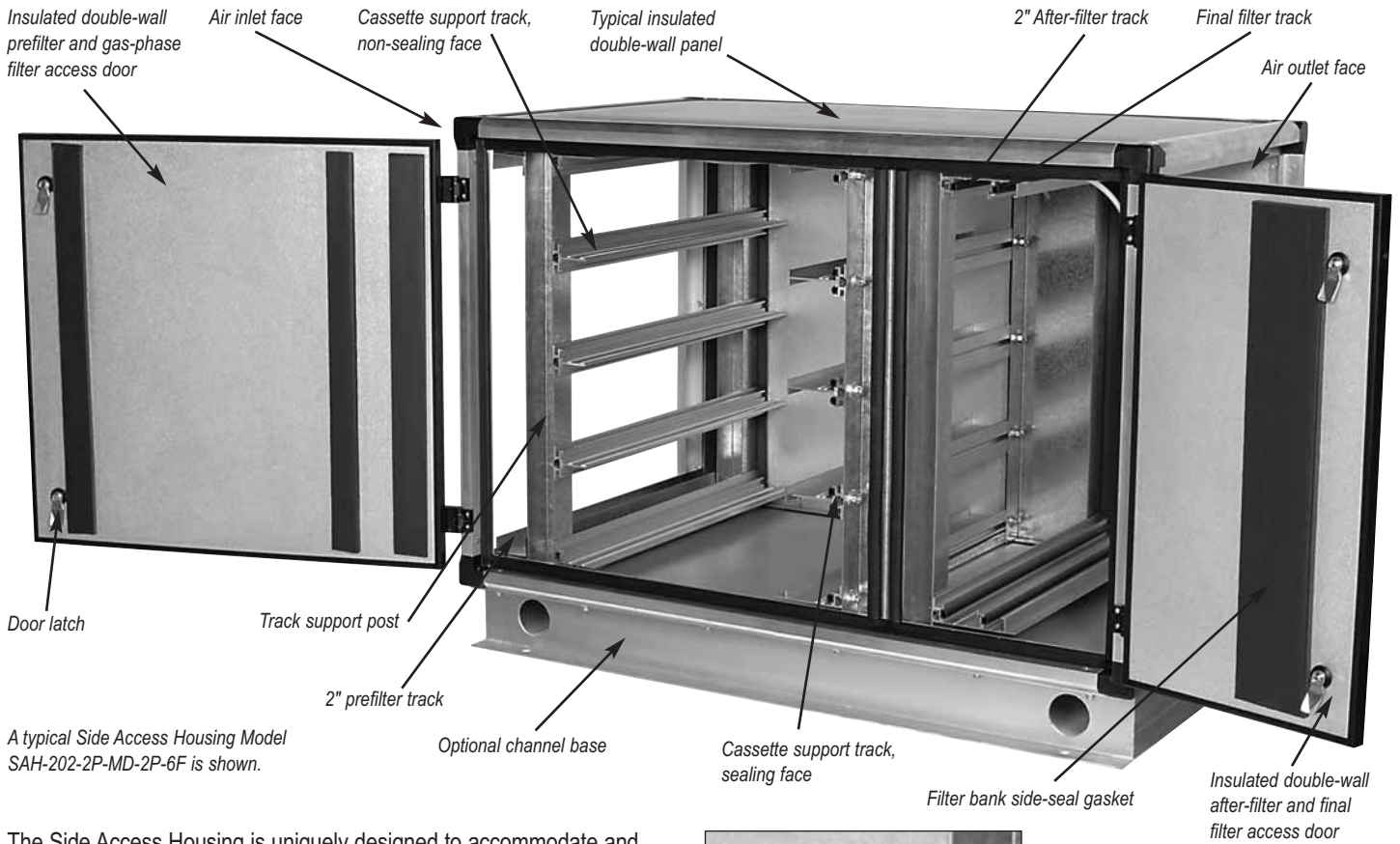

A typical Side Access Housing Model SAH-202-2P-MD-2P-6F is shown.

The Side Access Housing is uniquely designed to accommodate and securely seal AAF's gas-phase chemical filter cassettes. Each housing incorporates AAF's patent-pending filter sealing system to ensure that the contaminated air passes through the filter and does not by-pass around the filters. Typical details of the tracks are shown in the following illustrations. In some instances, depending on the equipment supplied and the filters required, minor track details may differ from those shown.

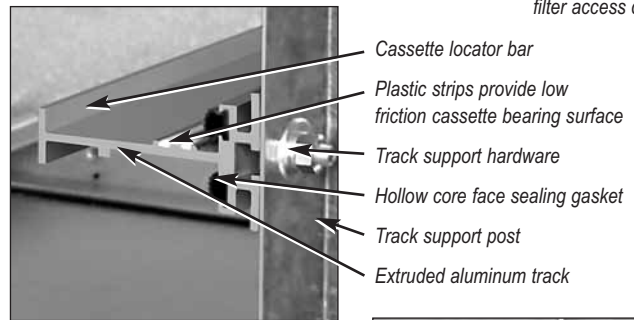

Cassette support track, sealing face.

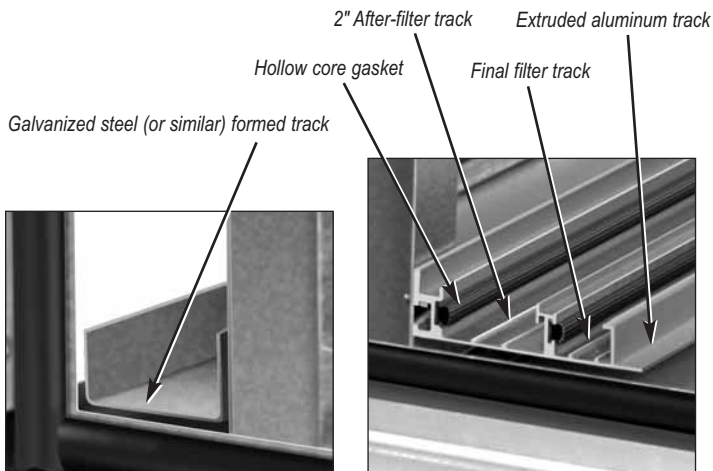

2" Prefilter Track

2" After-filter and final filter track. The final filter track shown is designed to accept a typical 1" nominal header style filter.

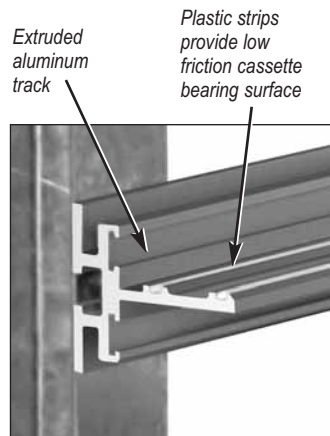

Cassette support track, non-sealing face

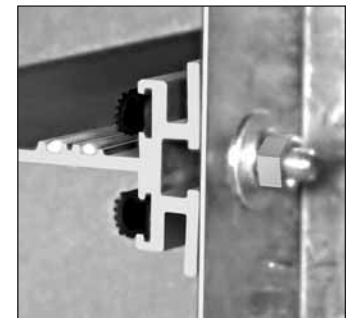

Track connection detail at support post. This detail shows AAF's "quick release" track installation method. Accurately located support post holes ensure high tolerance track spacing. Note that the track connection is completely isolated from the filter sealing surface and cannot interfere with filter installation.

3.4 General Filter System Installation Procedure

CAUTION

AAF offers particular optional modifications that must be included if the Side Access Housing is to be located outdoors where it will be exposed to the weather and sunlight. These include a weather cover, special door hardware, and modified and specially sealed panel joint construction. Make sure that the weather proof option has been included on the purchase order before installing the equipment outdoors.

3.4.1 Installing the Side Access Housing (SAH): Keeping the SAH on its shipping pallet, move it to its final installation location. Remove the restraints that secure the SAH to its pallet and remove any wrapping or packaging material.

! WARNING: The housing top will not support the weight of the unit. Any attempt to support the housing from the top may result in serious equipment damage and severe personal injury. Do not walk on the top of the unit or use the top for storage of materials.

3.4.2 Locating, Mounting, and Supporting the Side Access Housing (SAH): Locate the SAH in its final installation location. The support surface under the base of the frame shall be level, smooth, clean, and dry. The location shall not be subject to standing water or flooding. The circumference of the housing base shall be fully supported. Adjust the supports so that the base is level in all directions.

Anchoring the Housing: A suggestion for anchoring the standard housing is provided in Figure 2. If an optional channel base has been ordered the lower flange of the channel will include mounting holes. See the channel base photograph referenced in paragraph 1.2.3 for details.

Figure 2

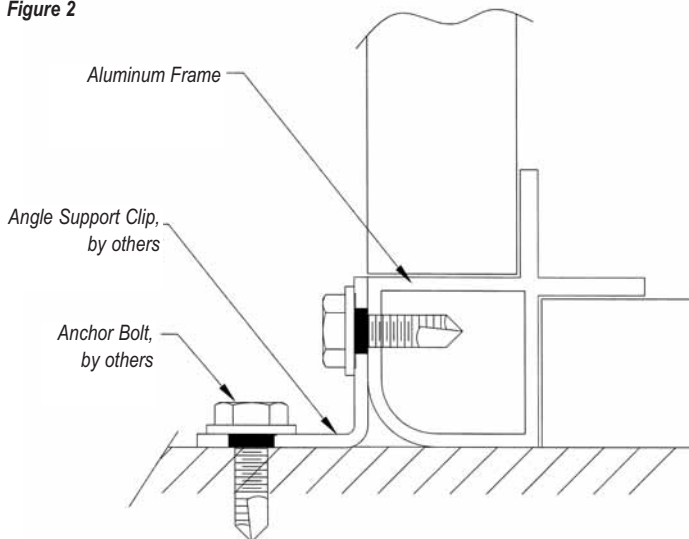

Hanging the Housing from a Ceiling:

The Side Access Housing has circular knockouts on the corner connections. Remove the knockouts and suspend the housing using 1/2" maximum diameter threaded rods, hardware and a cradle which includes C-channel and angle supports as suggested in Figure 3 below. Again, make sure that the circumference of the housing base is fully supported.



Figure 3

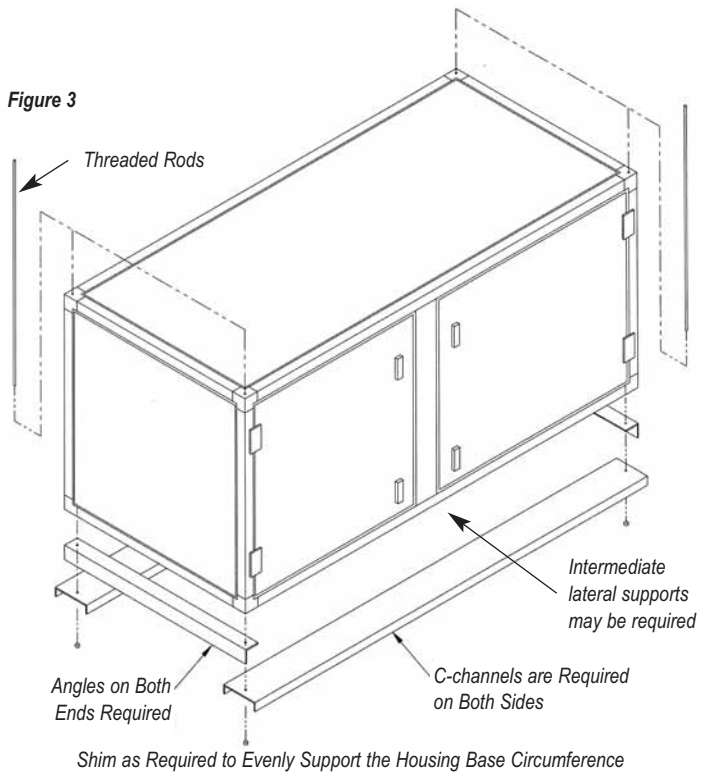

In all cases the foundation or support cradle and supporting structure shall be designed for each specific installation by a qualified professional engineer.

Provision of anchoring hardware, support cradles, or any other supporting component will be the responsibility of the installer or others. These items will not be supplied by AAF unless noted specifically in the AAF quotation and in the accepted customer purchase order.

3.4.3 Connection of Inlet and Outlet Ducts: Inlet and outlet ducts, when required, shall be connected to the inlet and outlet faces of the housing as shown in Figure 4.

Figure 4

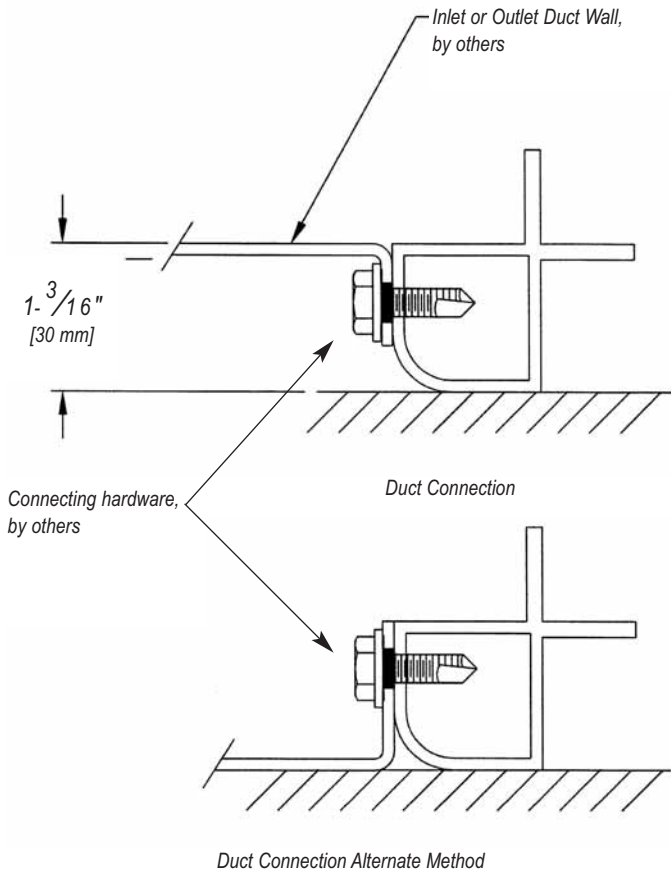

! WARNING: The housing is not designed to support the weight of inlet and outlet ducts. All ducts shall be supported independently of the housing. Any attempt to support the ducts from the housing may result in serious equipment damage and severe personal injury.

3.4.4 Sealing the Inlet and Outlet Duct Connections: Provide continuous gaskets, or caulk generously, between the flanges of the connecting ducts and the housing to prevent air leaks.

Provision of the inlet and outlet ducts, the connecting hardware, and the gaskets or caulk will be the responsibility of the installer or others. These items will not be supplied by AAF unless noted specifically in the AAF quotation and in the accepted customer purchase order. Any caulk used shall be a long life, flexible, non-drying caulking material. The caulk supplier shall ensure that the caulk shall meet the customer specifications for the application in which it is being used.

CAUTION

Many installations prohibit the use of certain caulking materials such as Silicone. The use of materials containing VOCs should also be avoided as they may have a negative effect on the life of the gas-phase filters.

3.5 Preparation for Filter Installation: In order to maximize the life of the gas-phase chemical filters and the particulate filters it is recommended that filter installation be the final installation task before start-up and commissioning of the system. In preparation for filter installation it is recommended that the following be completed:

- Completely clean the system to remove all construction debris and dirt, sweep, and vacuum to remove visible dirt.
- Damp wipe all surfaces to remove dust.
- Finalize and complete all caulking in the system.
- Finalize and complete all painting in the system.

It is recommended that all cleaning materials and paints used in the system be free of solvents. If this is unavoidable it is recommended that sufficient time be allowed for complete drying to occur and for the VOCs to disperse before installing the filters. This process can be accelerated by “blowing down” the system, i.e. operating the fan without the filters to ventilate the system. It is recommended that a blanket-style construction filter be installed at the inlet to the system to prevent construction dust from being drawn into the system. Consult with your AAF representative to obtain an appropriate product. Also, before “blowing down” the system check that it is safe to operate the fan without the pressure load of the gas-phase chemical filters. Consult the AAF submittal drawing for pressure information.

3.6 Prefilter Installation: It is highly recommended that prefilters be used to prevent the build-up of lint and dust on the face of the gas-phase chemical filters. If prefilters have not been provided elsewhere in the system ahead of the gas-phase filters they should be included in the Side Access Housing.

Install the prefilters as shown in the sequence shown below and at the top of page 10. The standard Side Access Housings are designed to accept 2" deep prefilters only. For best results, AAF recommends the use of the MERV 7 rated PerfectPleat®. The tracks are spaced and sized to accept 24" x 24", 12" x 24" and 24" x 12" nominal ASHRAE style filters.

Place the prefilter into the prefilter track with the pleats arranged vertically. However, it may be necessary when installing some half-size filters to arrange the pleats horizontally.



Step 1: Insert the prefilter into the track.



Step 2: Slide the prefilter in as far as it will go.



Step 3: The installed prefilter.

Repeat the process of prefilter installation until all tracks are filled with prefilters.

3.7 Gas-phase Chemical Filter Installation: The following instructions are specific to the installation of the Type MD gas-phase chemical filter cassettes into an SAH-XXX-2P-MD-2P-6F housing. Unless specifically mentioned otherwise, the procedure for installing the Type HD and Type CG cassettes will be exactly the same.

3.7.1 Preparing the Cassette for Installation: Remove the cassette from its carton and plastic bag. You will notice that each cassette or half-cassette is accompanied by a plastic bag containing loose gaskets (see top right). These are supplied specifically for use when the cassette is to be installed into an AAF Side Access Housing. These gaskets are critical for the sealing of the gas-phase cartridges to prevent by-pass of contaminated air around the filters.



Type MD half-cassette with butterfly and side gaskets.

Type HD half-cassette with butterfly and side gaskets.

(Note the Type CG cassette is not shown.)

Install the gaskets onto the cassettes and half-cassettes. The following pictures show the installation of gaskets onto a Type HD half-cassette. The process will be similar for the Type MD and Type CG cassettes.

Side gaskets:



Step 1: Remove the paper strip on the back of the black gasket to expose the adhesive.



Step 2: Locate the gasket on the leaving air side of the half-cassette along the edge of the cassette side plate. A gasket location guide has been formed into the side plate. The gasket should be located to the outside of this line.



Step 3: Firmly press the gasket into position so that it adheres to the side plate.

Step 4: Repeat to install the second side gasket on the other side of the half-cassette.

Butterfly-style face gaskets:



Step 1: Remove the paper strip on the back of the yellow "butterfly-style" face gasket to expose the adhesive.



Step 2: Locate the gasket on the edge of the leaving-air side face of the half-cassette as shown and firmly press the gasket into position so that it adheres to the face of the half-cassette.



Step 3: Repeat to install the second butterfly gasket on the other side of the leaving air side face of the half-cassette.



Step 4: The Type HD half-cassette is now ready for installation into the Side Access Housing.

The following picture shows a fully prepared Type MD half-cassette with gaskets attached.



3.7.2 Handling of the Cassette: The AAF SAAF Cassette is designed to be sturdy and to support a significant weight of chemical media. However, it should not be handled roughly. The cassette should always be lifted with two hands, one beneath each side panel as shown in the following installation pictures. The cassette should never be lifted, supported, carried or pulled by a single side panel.

3.7.3 Installation of the Cassettes in the Side Access Housing: Install the cassettes as shown in the sequence below starting with the bottom cassette. Slide each half-cassette into the SAH tracks and push it firmly into the enclosure until the side gasket on the first half-cassette is firmly compressed against the enclosure wall surface on the opposite side from the access door on housings accessed from one side. The plastic edge of the final cassette should be even with the outer edge of the extruded aluminum track. Repeat this process until the tracks at each level have been filled.

On housings with access doors on both sides, insert half of the half-cassettes from one side and the other half from the other side.

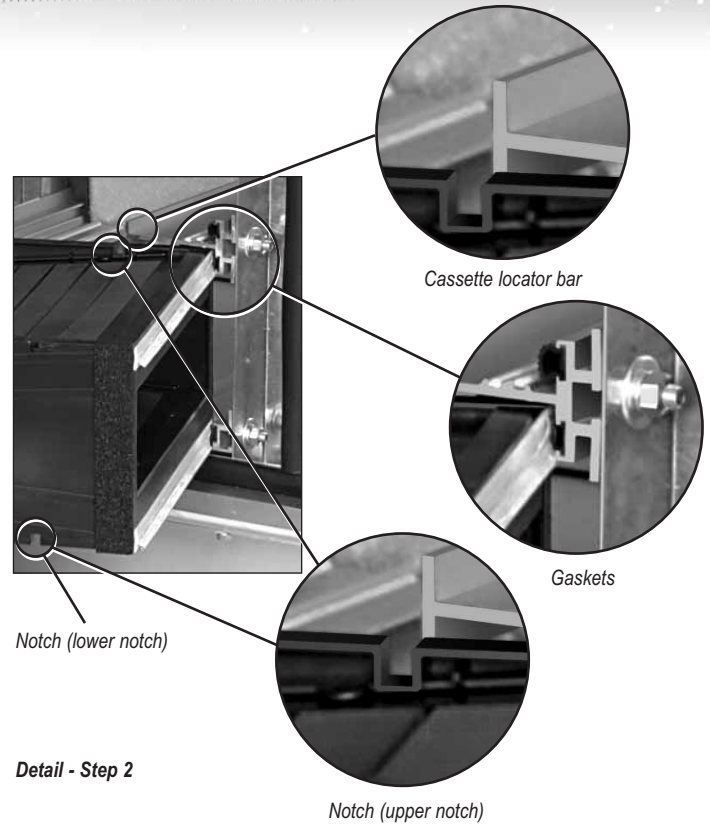

Detail - Step 2

Notch (upper notch)



Step 1: Prepare to install the half-cassette. Address the air outlet side sealing track at a slight angle as shown.



Step 3: Rotate the cassette slightly so that the vertical locator bars are inserted into the slots in the half-cassette while maintaining the compression between the hollow core and butterfly gaskets. See Detail 1 – Step 3 and Detail 2 – Step 3.



Step 2: Engage the upper and lower black hollow core gaskets in the tracks with the yellow butterfly gaskets on the half-cassette, see Detail – Step 2. Also, begin to align the upper and lower notches in the half-cassette with the vertical cassette locator bars which form part of the track.

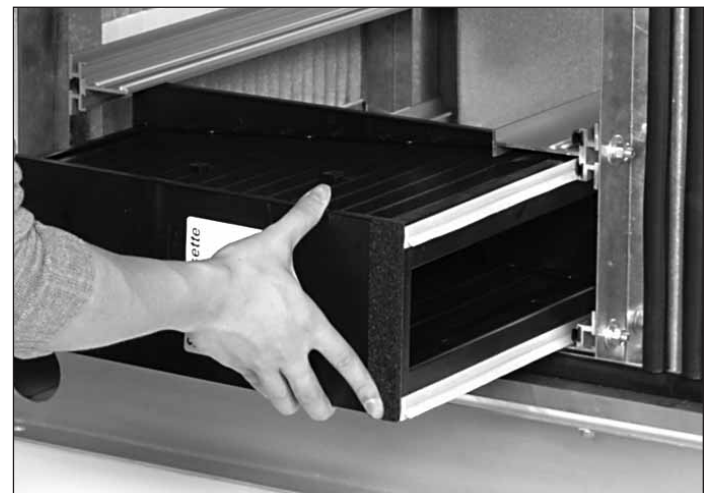

Detail 1 - Step 3

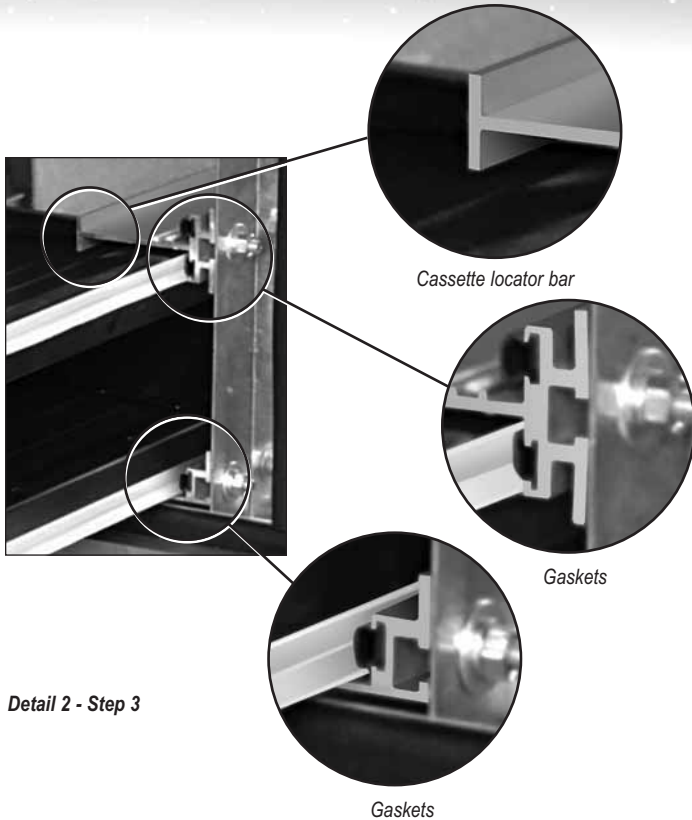

Detail 2 - Step 3

3.8 After-filter Installation: It is recommended that a temporary after-filter be installed in the system to collect an initial plume of dust that might be blown from the gas-phase chemical filters. If after-filters have not been provided elsewhere in the system following the gas-phase filters they should be included in the Side Access Housing. The installation of the after-filters is exactly the same process as described for the prefilters in 3.6. See below:



Step 1: Insert the after-filter into the track.



Step 4: Maintaining a steady and even force on the side of the cassette push it into the housing to engage the notches on the outer side of the half-cassette and continue to insert the half-cassette until it is fully installed.

Repeat the process of gas-phase cassette installation and sealing until all SAH modules are filled with sealed cassettes as shown below.



Step 2: The installed after-filter.

Repeat the process of after-filter installation until all tracks are filled with after-filters.

3.9 High Efficiency Final Filter Installation: A high efficiency final filter bank is often required to ensure that the filtered air meets the highest levels of particulate cleanliness. The standard Side Access Housings are designed to accept a 6" deep single header final filter only. For best results AAF recommends the use of one of its line of single header M-Pak high efficiency filters. The tracks are spaced and sized to accept 24" x 24", 12" x 24" and 24" x 12" nominal ASHRAE style filters.

If a final filter is provided with the system, place the high efficiency final filter into the filter track with the pleats arranged vertically. However, it may be necessary when installing some half-size filters to arrange the pleats horizontally.

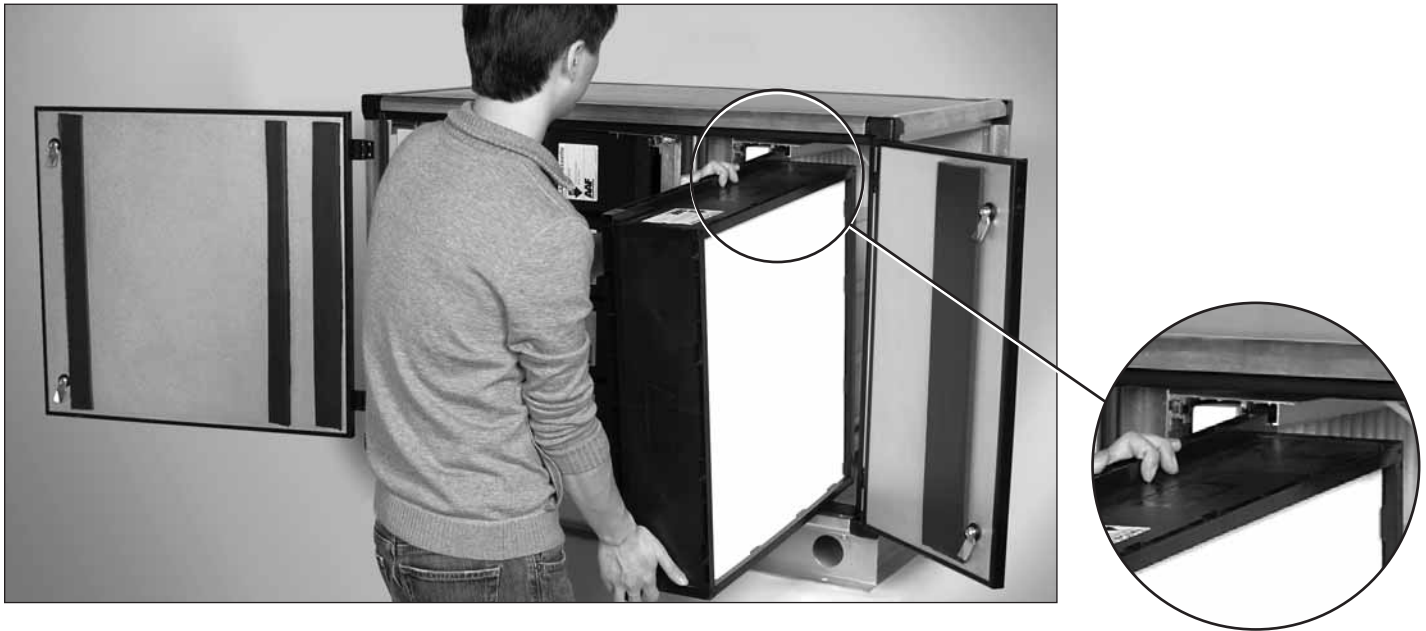

Step 1: Insert the high efficiency M-Pak filter into the track.



Step 2: The installed high efficiency M-Pak filter.

Repeat the process of high efficiency filter installation until all tracks are filled with high efficiency filters.

3.10 Latch SAH Doors: Now close and latch the SAH doors as shown.



Side Access Housing with wall-mounted gauges.

3.11 Pressure Gauge: It is recommended that pressure gauges be installed across the filter system to indicate when the particulate filters, being the prefilter, after-filter, and high efficiency filters, need to be replaced. The pressure gauge will register the pressure differential across each filter bank. As the particulate filter loads with dirt the resistance to the airflow, and consequently, the pressure across the filter will increase. The pressure across the gas-phase chemical filter(s) will remain constant since these filters collect gas molecules and not particulate. Pressure gauges across the gas-phase filter banks are typically not required but may be supplied if specifically requested. The pressure gauges are normally ordered as part of the housing and will be supplied in one of the installations shown on the right.

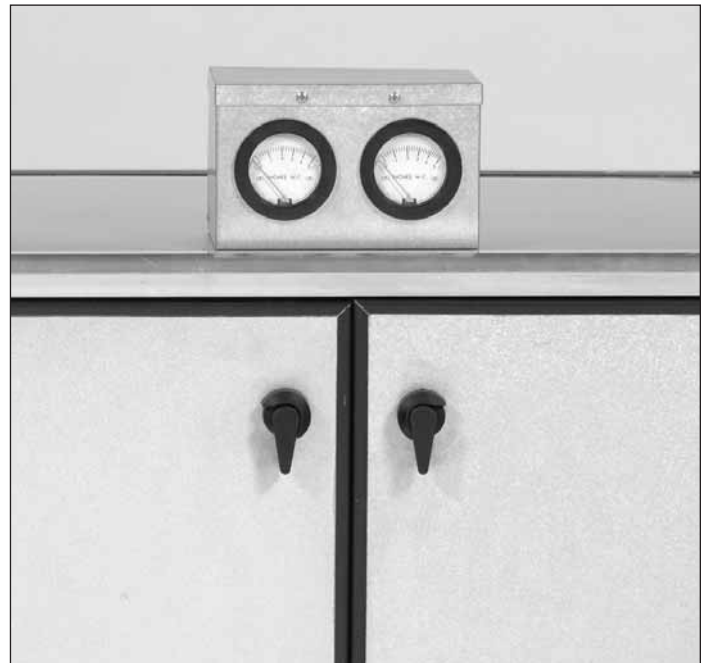

Side Access Housing with top mounted gauges.

Figure 5

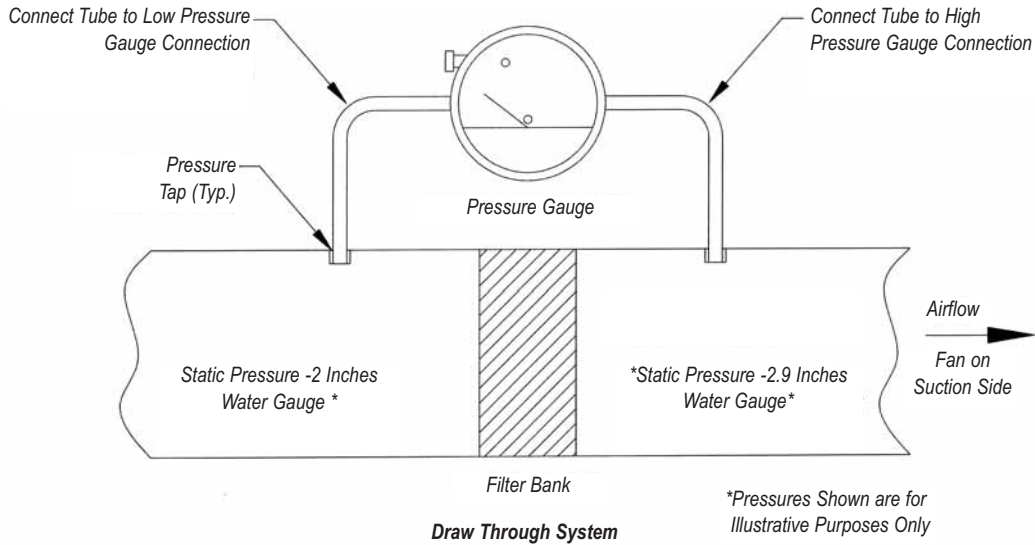
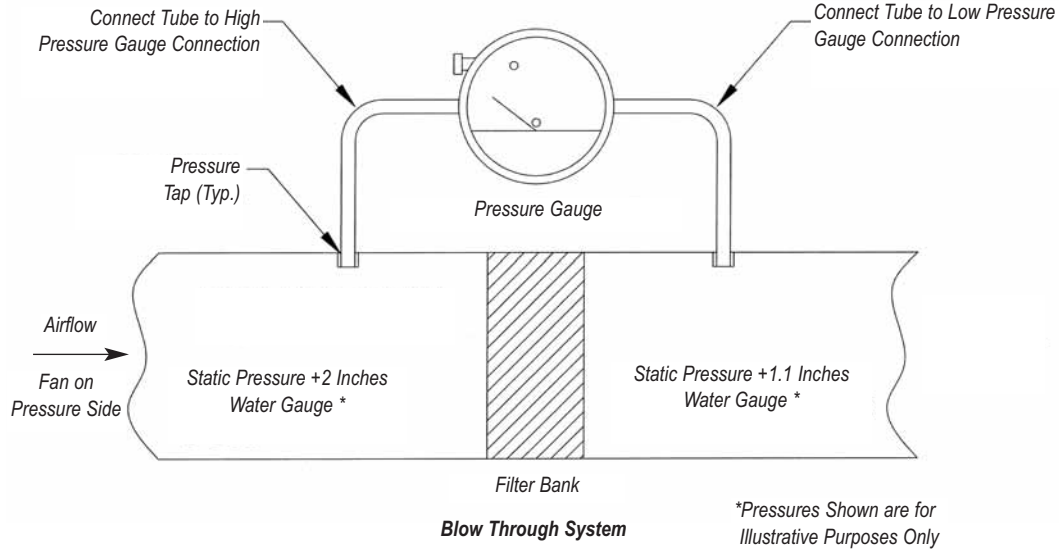

Figure 6



Top-mounted gauges may ship separately to prevent the possibility of shipping damage to the gauge enclosure and gauges. In this case some simple installation will be required. The gauge(s) will ship installed in an enclosure which will be screwed to the top of the SAH. Pressure taps will be supplied on the housing on each side of the filter. These will be required to be connected to the gauge, using 1/4" diameter clear plastic tubing, as shown in Figures 5 and 6. When the gauge option is ordered the tubing will be supplied by AAF with the gauge and gauge enclosure. Refer also to the specific installation instructions supplied with the gauge(s).

If pressure gauge(s) have not been included in the customer's purchase order discuss the pressure gauge options with your AAF representative.

3.12 Fans: Sometimes the SAH may be supplied with an internally mounted fan. See the AAF submittal drawing and wiring diagram for information and details. In order for the fan to be operated some or all of the following installation steps may be required:

CAUTION: All electrical work must be carried out in accordance with all appropriate governing electrical codes and standards.

! WARNING: All electrical work has the potential to cause shock, injury, and even death. Disconnect all power whenever working on the system. Only qualified electrical personnel should work on the system at any time.

3.12.1 Provision of an appropriate power supply as specified in the submittal information.

CAUTION: Use of the incorrect line voltage may result in irreparable damage to electrical components.

3.12.2 Provision, installation and wiring of a properly sized motor starter and disconnect with fuses / circuit breakers as required. These components will normally be supplied by the owner or installer.

CAUTION: An electrical disconnect shall be incorporated into the power wiring and mounted adjacent to the equipment so that power can be cut when required during start-up and maintenance. The disconnect will typically be supplied by others.

3.12.3 Wiring of the Motor Starter to the Fan:

3.12.4 Provision, installation and wiring of any special controls, and interconnecting wiring to associated equipment such as dampers, air flow monitors, chemical sensors, etc.

For guidelines on fan selection see paragraph 9.1

4.0 Start-up Instructions

When the fan system is started up ensure that the airflow volume is controlled so that the actual airflow velocity across the filter system does not exceed the rated face velocity shown on the AAF submittal drawing. If there is any doubt about the required face velocity the default maximum velocities shall be as follows:

- **MD and CG cassettes:** 500 feet per minute
- **HD cassettes:** 250 feet per minute

Immediately on start-up examine the filter system for any apparent air leaks or other anomalies. Air leaks may be detected by noise or by use of a synthetic smoke puffing device at the external joints and seams of the filter system installation. Correct or repair any discrepancies, as necessary. Repeat this examination after 24 hours of operation and again after one week of operation.

Monitor the pressure drop across the filter system to ensure that the filters are operating within the pressure range expected and to ensure that the pressure drop is not too high. Consult the AAF drawing for the expected clean filter pressure differentials.

5.0 Maintenance

5.1 Prefilter: If a prefilter has been included as part of the system, record the pressure drop weekly to obtain the status of the particulate filter. A normal particulate filter can be expected to last between 2 and 3 months before reaching its final recommended pressure drop (see the AAF drawings for details). However, under heavier or lighter dust loading conditions, this may vary. At an airflow velocity of 500 feet per minute, the 2" deep AAF PerfectPleat filter can be expected to have an initial pressure drop in the range of 0.35" w.g. The recommended final pressure drop is 1.0" w.g. This means that when a pressure drop increase of 0.65" w.g. has been recorded it is time to change the prefilter.

5.2 After-filter: If an after-filter has been installed in the system to collect an initial plume of dust that might be blown from the gas-phase chemical filters, it can eventually be removed from the system to reduce the energy required to operate the system. Monitor the pressure drop across this filter and when the pressure ceases to increase it is safe to remove this filter from the system. This should typically be no longer than after 40 hours of operation. If after-filters still have significant life remaining at the time of removal (based on the pressure drop reading) they should be retained for reuse as after-filters following the change-out of the chemical filters or be used as replacements for the prefilters.

5.3 High Efficiency Final Filters: If a high efficiency final filter has been included as part of the system, record the pressure drop weekly to obtain the status of the filter. A normal high efficiency filter can be expected to last for one year or more before reaching its final recommended pressure drop (see the AAF drawings for details). However under heavier or lighter dust loading conditions this may vary. At an airflow velocity of 500 feet per minute the 6" deep AAF M-Pak filter can be expected to have an initial pressure drop in the range of 0.55" w.g. The recommended final pressure drop is 1.5" w.g. This means that when a pressure drop increase of 0.95" w.g. has been recorded it is time to change the high efficiency filter.

5.4 Gas-phase Filter Monitoring: A discussion of sophisticated gas-phase filter monitoring is beyond the scope of this manual. At its most simple, when the filter is used to remove nuisance odors, the time to change out the gas-phase chemical media cassette is when the odor begins to be regularly detected on the clean side of the filter system. In more stringent applications where the system is supplied to protect health and/or high value plant and product, active real time electronic and passive coupon corrosion monitoring systems are available to determine the performance of the system. The remaining life of the media in the SAAF Cassette can be determined by taking a sample of media and returning it to AAF for analysis. Consult with your AAF representative regarding active and passive monitoring systems and media sampling for remaining life analysis.

5.5 Removal and Replacement of Particulate and Gas-phase Chemical Filters: Removal of filters will be the reverse of the installation process described earlier in this manual. Filter replacement will be carried out exactly the same as at initial installation.

5.6 Disposal of Used Filters: Used chemical filters and particulate filters shall be packaged and disposed of in full accordance with all required and applicable laws and regulations. Consult with local environmental control authorities such as local, state, and federal EPA & OSHA authorities for direction. Material Safety Data Sheets (MSDS) are available on all products supplied by AAF. Contact your AAF representative for further information.

5.7 Gas-phase Chemical Filter Cassette Face Sealing Gaskets:

The proper maintenance of the hollow core gaskets located in the track on the leaving air, or sealing, face of each cassette is critical to the performance of the system. Check the gaskets carefully whenever the gas-phase chemical filters are replaced. If gaskets are worn, frayed, or damaged in any way they should be replaced. Check the seal between the gas-phase chemical filter cassette and the hollow core gasket on the air leaving face of the gas-phase cassettes whenever new SAAF Cassettes are installed.

5.8 After-Filter and High Efficiency Particulate Filter Sealing Gaskets:

The proper maintenance of the hollow core gaskets located in the after-filter and high efficiency particulate filter tracks are critical to the performance of the system. Check the gaskets carefully whenever the after-filters and high efficiency particulate filters are replaced. If gaskets are worn, frayed, or damaged in any way they should be replaced. Check the seal between the filters and the hollow core gaskets whenever new particulate filters are installed.

5.9 Access Door Sealing Gaskets: The proper maintenance of the access door sealing gaskets is critical to the performance of the system. Check the gaskets carefully whenever the gas-phase chemical filters are replaced. If gaskets are worn, frayed, or damaged in any way they should be replaced. Check the seal between the door and the housing whenever new SAAF Cassettes are installed.

5.10 General System Maintenance: Ducts, external SAH surfaces, access doors, and other system infrastructure should be checked at least every 6 months. Internal SAH surfaces shall be examined whenever filters are replaced. Examine all components for the following:

5.10.1 Cleanliness: Sweep and vacuum all standing dust or dirt in the system and damp wipe all surfaces. Be mindful of the impact of cleaning solvents on the performance and life of the gas-phase chemical filters and take appropriate precautions to protect the system.

5.10.2 Water: The system should be completely dry at all times. The presence of standing water, condensation, or dampness is detrimental to the performance and life of the system. Determine and remove the cause for the presence of water in the system, dry the system, and examine all components for the presence of mold and other biological growth. Remove all contamination, clean, and sterilize as necessary.

5.10.3 Filter System Integrity: Ensure that all filter frames contain the appropriate filter elements, both particulate and gas-phase, and that these elements are correctly installed. Check for missing or improperly installed components and review the filter seals. Check for air leaks at joints and seams and replace gaskets, worn hardware, and seal with caulk as necessary.

5.10.4 Duct and System Integrity: Examine the entire system to ensure that contaminated air cannot leak around the filter system. Check all perimeter seals and repair as necessary.

5.10.5 Corrosion: If metal components are corroded repair the corrosion and provide protective coatings as necessary. Be mindful of the impact of painting on the performance and life of the gas-phase chemical filters and take appropriate precautions to protect the system. Determine the source of the corrosion and rectify.

6.0 Troubleshooting

6.1 High Pressure Drop Reading Across the Filter System:

6.1.1 High Dust Loading: The most probable cause of high pressure drop will be high dust loading of the particulate filters. The rate of dust loading may not always be constant and may be significantly affected by season and location, e.g. the timing of pollen blooms, production schedules, and rural versus urban locations.

6.1.2 High Airflow Volume: High airflow volume may result from improper fan sizing or improper control of the fan. When clean particulate filters are installed in the system the pressure drop across the system will decrease and the airflow will normally increase. The airflow should be controlled through the use of modulating dampers which are designed to keep the system pressure constant or with the use of variable speed drives. The filter system may also be slightly oversized so that it will handle the higher airflow at the lowest system pressure without exceeding the recommended filter face velocity.

6.1.3 Condensation: Humid air combined with cold surfaces may result in condensation of moisture and blinding of both the particulate and gas-phase filters. This moisture can also result in mold growth and corrosion which may also impact the performance of the filter system. If condensation is a recurring problem dehumidification or other tempering of the air may be required. Additional system insulation may also be necessary. If the source of the moisture is at the intake, weather hoods, or weather louvers to remove sensible moisture in the form of rain should be considered. If the source of moisture is from leaking ducts repair the leaks.

6.1.4 Freezing: On air intake systems the presence of moisture in the filters when caused by or combined with condensation, rain, snow, sleet, or ice, and when subjected to freezing temperatures, can cause the filters to freeze and become impassible. In such cases provide intake protection systems to remove the cause of the problem.

6.2 Visible Discharge of Particulate:

6.2.1 Check for missing or damaged filters and system leaks. Replace filters and reseal as necessary.

6.2.2 Provide higher efficiency filters on the downstream side (air leaving side) of the system.

6.3 Odors and Smells:

6.3.1 Check the performance of the gas-phase chemical filters. If the filters are no longer effective replace them.

6.3.2 Check for missing or damaged filters and system leaks. Replace filters and reseal as necessary.

7.0 Spare Parts List

It is recommended that the following spare parts be stored at the installation site for routine maintenance purposes. The quantities required will depend on the size of the system. Consult with your AAF representative to determine actual quantities required. Minimum recommended quantities are provided in the table below.

AAF Part Number	Description	Recommended Spares
Refer to the original customer purchase order and the AAF submittal drawing.	SAAF cassette gas-phase chemical filters	One full replacement set of each type included in the system.
Refer to the original customer purchase order and the AAF submittal drawing	Particulate filters	One full replacement set of each type included in the system.
2500932	Extruded plastic strips which provide low friction cassette bearing surface	20% of the number supplied with the equipment
2500924	Hollow core track gasket	One full replacement set or a roll of 50 feet
2500981	Access door perimeter gasket	One full replacement set or a roll of 50 feet
2500999	Access door side seal gasket	One full replacement set

To order replacement parts call: **1-800-477-1214**.

8.0 Equipment Characteristics, Dimensions, Operating Weights, and Shipping Weights

See the AAF submittal drawing supplied on the specific order.

9.0 Technical Guidelines

9.1 Fan selection and sizing: The following guidelines are provided for the following purposes:

- To assist the user in selecting a fan to operate with the AAF filter system.
- To inform the user of the criteria used by AAF to select an integral fan that is provided with an AAF Side Access Housings (SAH).

9.1.1 Determination of Fan Selection Pressure Drop: The following concerns initial and final filter pressure drop and the use of pressure drop for fan selection. AAF's standard product literature indicates the start-up, being the clean filter or initial, and the recommended final, or dirty filter, pressure drops for all filters at a particular airflow velocity. If the airflow velocity in the actual installation differs from that referenced in the literature then the start-up (initial) pressure drop will also differ. For instance, an AAF PerfectPleat or M-Pak filter is typically rated at 500 FPM velocity, however, when used with a type HD cassette the airflow velocity will normally be 250 FPM so the initial pressure drop will be lower. Similarly, the final pressure drop referenced in the literature is a "recommended" value only and the filter may be changed out at a lower pressure drop, if required.

AmericanAirFilter®

SAAF Side Access Housings (SAH) with SAAF Cassette Gas-phase Chemical Filters

Installation, Operation, and Maintenance Instructions

9.1.1 continued

A typical pressure drop profile for an SAH might be as shown in Table 3 below:

Table 3: Nominal Pressure Drop (ΔP) @ 250 fpm Nominal Airflow Velocity

Pressure Component	Initial ΔP (in. w.g.)	Final ΔP (in. w.g.), Recommended or Actual
External pressure loss from inlet and outlet ducts	1.0	1.0
2" PerfectPleat	0.11	1.0
HD Cassette with SAAF Oxidant	0.73	0.73
HD Cassette with SAAF Oxidant	0.73	0.73
After-filter	0	0
M-Pak Filter	0.23	1.5
TOTALS	2.80	4.96

9.1.2 Issues to be Considered When Selecting the Fan: There are a number of issues to be considered when determining the fan design and selection criteria:

1. If the fan is selected for the maximum pressure drop shown (4.96 in. w.g.) then it will have been selected for an operating point that will rarely occur. This may be inefficient in terms of energy usage (motor HP), physical fan size, and product cost.
2. If the fan is selected for the maximum pressure drop shown (4.96 in. w.g.) then it will deliver far more than the required airflow at the lower start-up pressure drop (2.80 in. w.g.). Unless the airflow is controlled by using balancing dampers or a variable speed drive this may result in discomfort from high discharge velocities, high noise levels, high energy use, and inefficient filter performance.
3. Conversely, if the fan is selected for the minimum pressure drop shown (2.80 in. w.g.) then it will deliver far less than the required airflow at the higher final pressure drop (4.96 in. w.g.). This may result in inadequate air supply. Alternatively the filters can be replaced before they reach their final recommended pressure drop which results in higher filter replacement costs.

Other factors to be considered are:

4. The space available inside the cabinet. This may limit the fan style or size that can be accommodated within the cabinet. This may require the use of an external stand-alone fan.
5. The costs associated with providing non-standard fans or fan or motor control systems.
6. The type of fan to be selected. For instance will a non-overloading fan wheel be required.
7. Power available in terms of voltage, phase, and frequency.
8. Special parameters such as special electrical, environmental, explosion, or temperature requirements,

As is evident from this discussion there are a number of factors to be considered when selecting the appropriate fan.

9.1.3 AAF's Policy Regarding the Provision of Internally Mounted Fans: Items 1 & 2 are standard offerings, item 3 is an option:

1. When the size of the cabinet allows, AAF will supply a fan capable of generating the design airflow at the average pressure drop through the system. In the case of the table above the average pressure drop is $0.5 \times (2.8 + 4.96) = 3.88$ in. w.g. An external pressure drop of 0.1 in. w.g. will be assumed. A backward inclined non-overloading fan wheel will be supplied unless otherwise advised.
2. When the size of the cabinet limits the fan selection (normally on smaller SAH sizes such as size 102 through 204) AAF will advise the maximum performance that can be supplied by a fan that will fit into the space available. An external pressure drop of 0.1 in. w.g. will be assumed. A backward inclined non-overloading fan wheel will be supplied unless otherwise advised.
3. When the customer specifies a fan performance that is different from that based on the design airflow at the average pressure drop through the system and the size of the cabinet is not an obstacle AAF will select a fan to meet the specified requirements.

See AAF's submittal drawing for the order in question for the details of the fan supplied and its performance.

